

Product Description

FrameOne – beauty in the workplace
FrameOne is the result of the union between high design and functionality. It is a source of emotion, as it helps people identify with their work. And it is a source of inspiration and innovation, two key criteria for successful organisations and their employees.

FrameOne rectangular desk

- ① Rectangular Table Top (W800mm x D600mm)
- ② Under structure

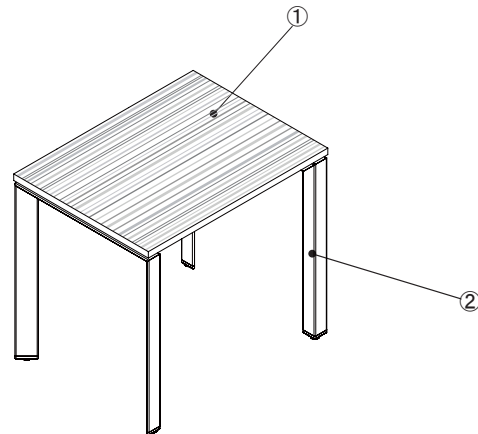
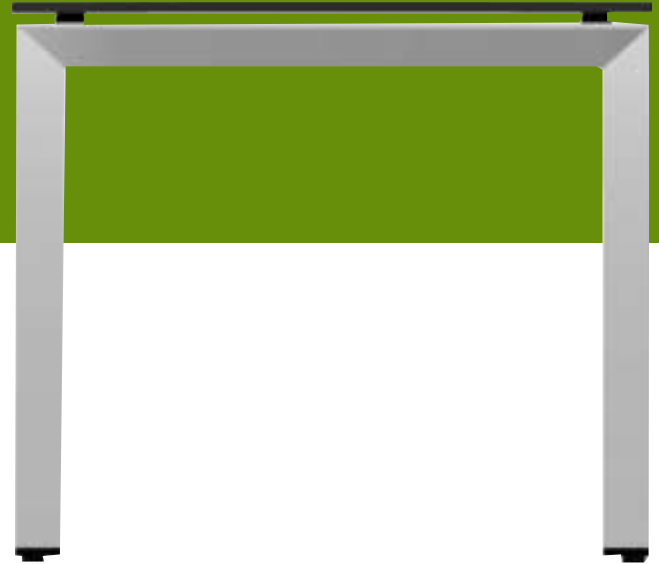

Material Declaration

The **FrameOne Desk** consists of the materials listed below. The total weight is **29.8kg**.

Metals	kg	%	Plastics	kg	%	Others	kg	%
Steel	12.64	74	PA6 30GF	2.60	8.7	Particle Board	12.73	43
Extruded Aluminum	1.883	6						

Manufacturer

The selected product **FrameOne Desk** is manufactured in Steelcase Manufacturing Malaysia in Puchong (Malaysia).

Steelcase, which was founded in 1912, has been dedicated to creating innovative products and helping people work more effectively for almost a century. Steelcase has management systems for Quality (ISO 9001) and for the Environment (ISO 14001), ensuring that our customers are guaranteed the same level of product quality and environmental performance, wherever they are in the world.

Steelcase is committed to continually reducing the environmental impacts of its products and activities on a global scale.

For further information see www.steelcase.com/ap

Life cycle stages



Materials

The stage includes raw materials extraction and transformation into material ready to be used.

Production

This stage comprises all production and assembly processes taking place at Steelcase or at suppliers.

Transport

Transport from suppliers to the production site and transport from the production site to Asia Pacific markets is considered.

Use

No relevant environmental exchanges occur during use of the product.

End of life

Any product can be disposed in different ways and also base on the availabilities of recycle center at the particular market. Steelcase product used high recycle content materials and is also recyclable as to sustain the environment together.

Recycle Content Calculation

Description	Weight(Kg)	Percentage (%)
Recycled Content (%)	22.1	74%
Post Consumer Recycle Content (%)	8.3	28%
Pre Consumer Recycle Content (%)	13.7	46%
Recyclable Content (%)	17.1	57%
Total Weight (Kg)	29.8	100%



Environmental life cycle

End of life

- **FrameOne Desk is 57%** recyclable content by weight.
 - All materials of the packaging are 100% recyclable.

Materials

- The **FrameOne Desk** total weight is **29.8kg**.
FrameOne Desk make out of **74%** of recycle content materials.
 - The packaging used is from **100%** recycle materials and **100%** recyclable.
 - **FrameOne Desk** is made from minimum amount of components and different materials.

Use

- **FrameOne Desk** is design for long product life cycle.

Transport

- The packaging volume of the **FrameOne Desk** is minimised and help us to improve filling rates and thus require less energy for shipping. Indirectly reduce the amount of carbon footprint.

Production

- The production site is certified with ISO9001 and ISO14001.
- Powder coat painting is VOC free and free of heavy metal.

Disclaimer :

Numbers may vary based on model and options selected. Calculations of recycled content are based on data provided by suppliers and other available information. This data may include industry averages, ranges or other broadly based information. Steelcase makes conservative assumptions when compiling this information to provide the most accurate recycled content calculations possible but variability in market conditions or manufacturing processes may result in higher or lower content. This document will be reviewed and updated periodically and is subject to change without notice.